

USE: Customer provided and installed J-6 base

EXCAVATION AND DUCT PLACEMENT FOR THREE PHASE FEEDER JUNCTION CABINET, 600A (J-6)

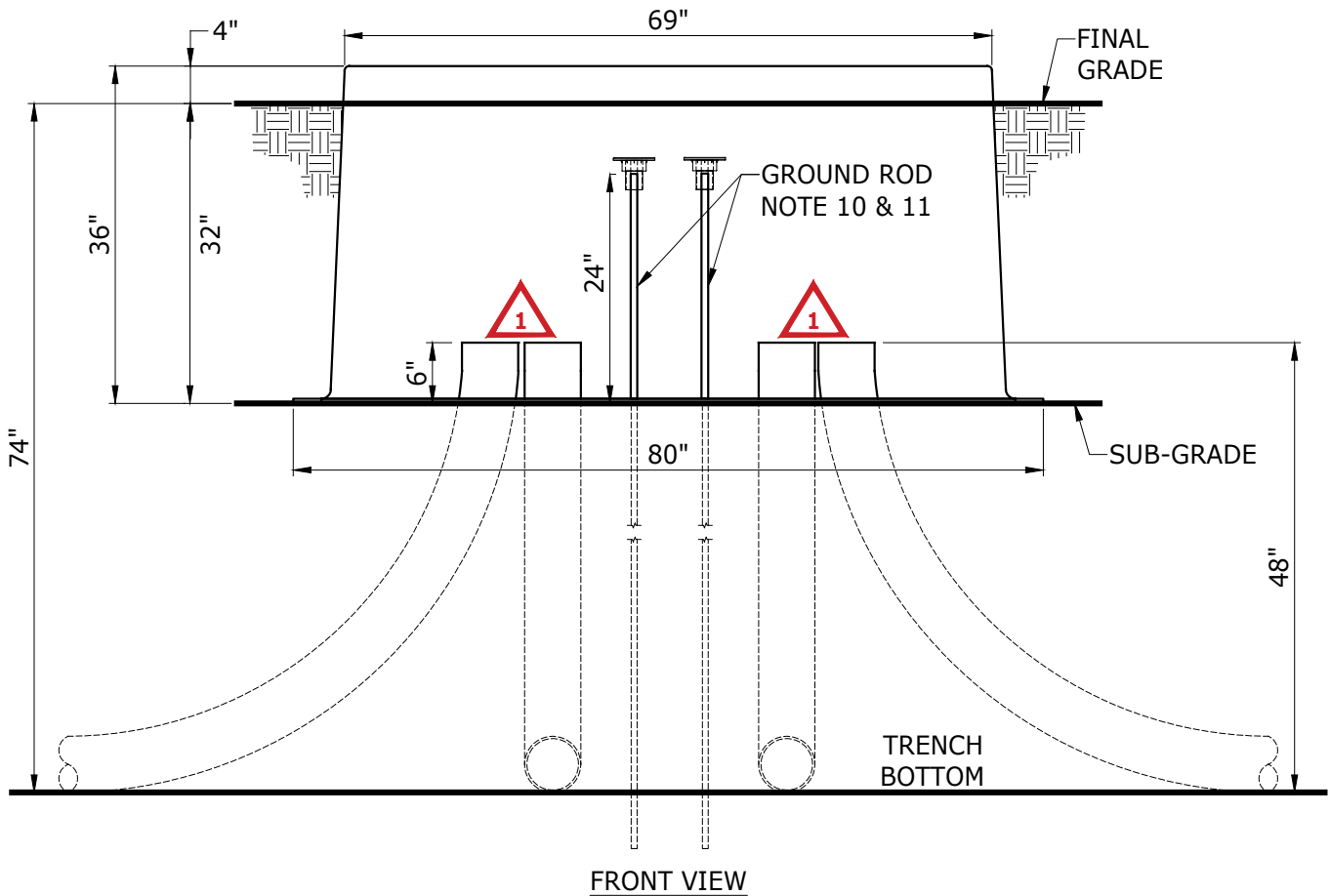
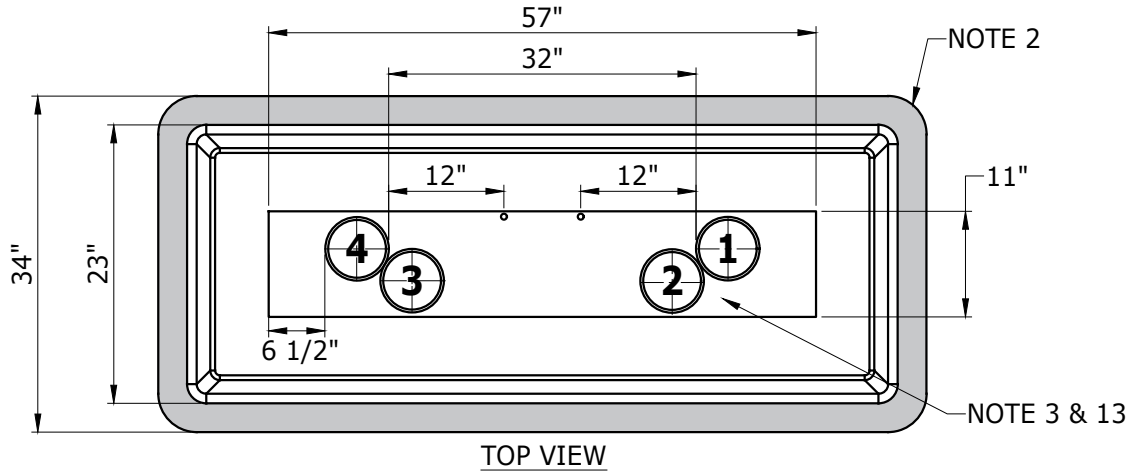

FIGURE 1
J6 CABINET BASE AND DUCT

		INITIATED BY	JAB	REVISION NO.	1	SR-236
		ESR COMM.	10-23	ESR COMM.	10-25	
				EFFECTIVE DATE	10-25	

USE: Customer provided and installed J-6 base

EXCAVATION AND DUCT PLACEMENT FOR THREE PHASE FEEDER JUNCTION CABINET, 600A (J-6)

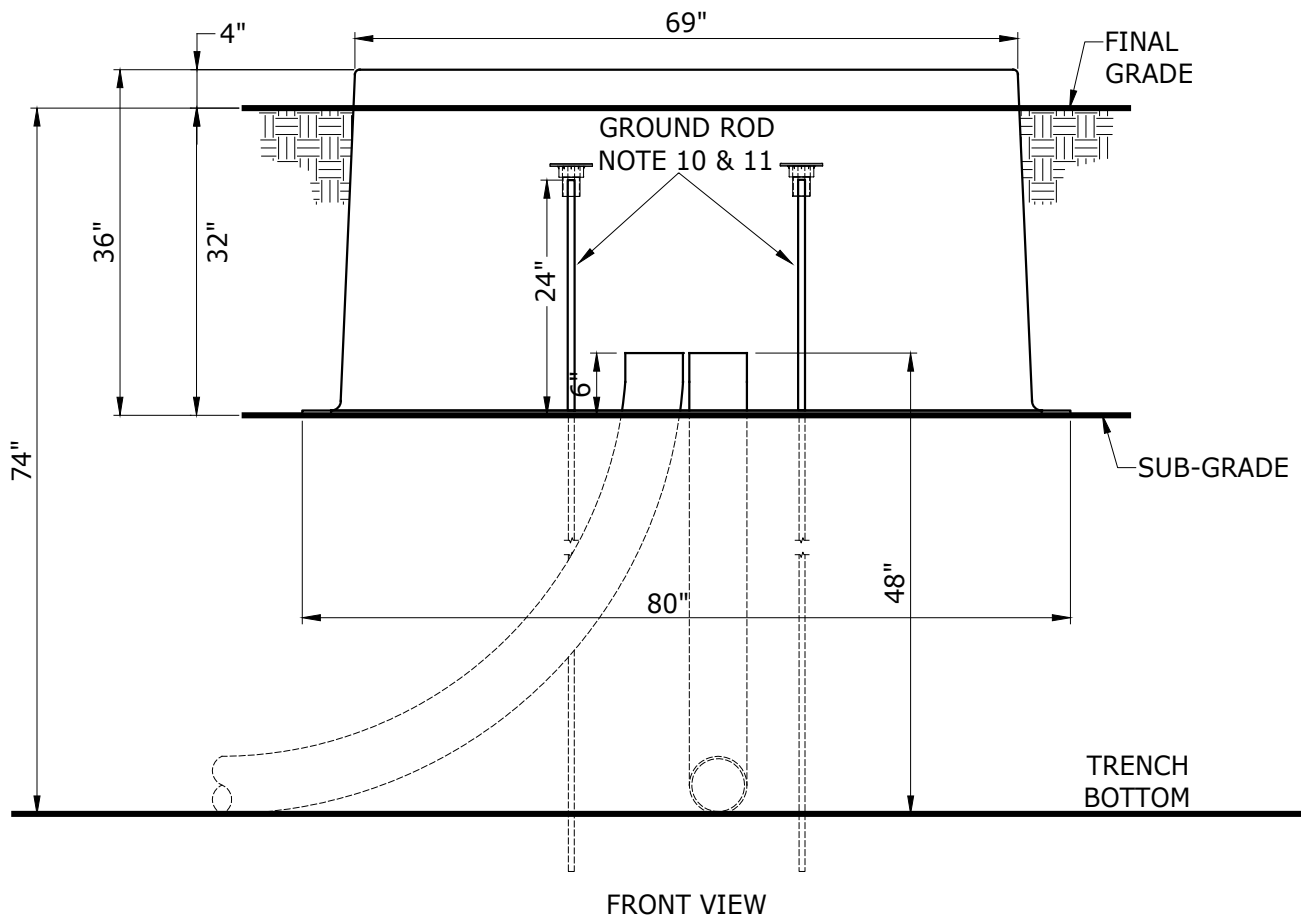
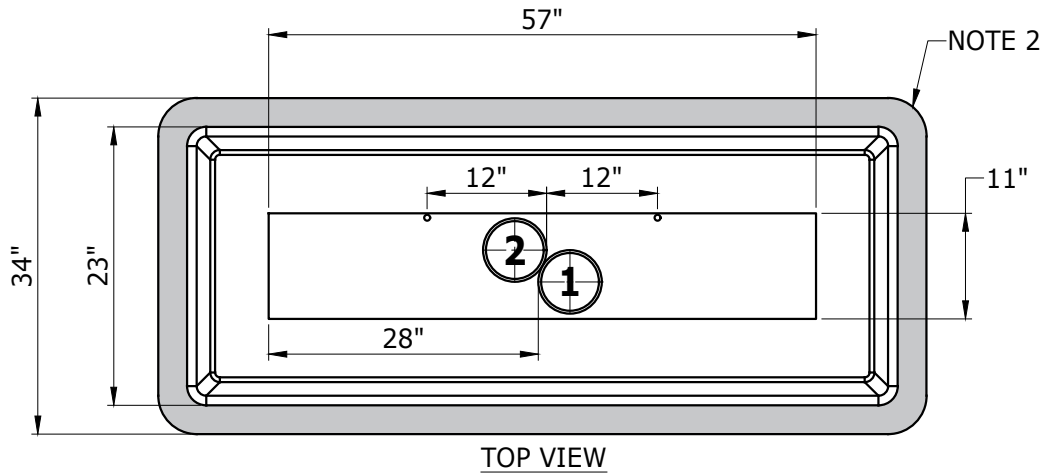

FIGURE 2
SINGLE BUS J6 CABINET BASE AND DUCT

USE: Customer provided and installed J-6 base

EXCAVATION AND DUCT PLACEMENT FOR THREE PHASE FEEDER JUNCTION CABINET, 600A (J-6)



NOTES:

1. The junction cabinet base is an integral part of the cabinet and shall be provided, installed and backfilled by the Customer. Approved base must be utilized, Concast, Fibercrete FC box pad, Cat. No. **FC-23-69-36-TEP**.
2. Excavation for installation of box pad shall be 82" x 36" x 32" deep, soil shall be compacted and level prior to box pad placement.
3. Customer to provide and install 6 inch duct and four - 48 inch x 90 degree radius PVC duct sweeps as depicted on construction drawing and detail sheets provided by Design Services. Duct placement shown in Figure 1 is for reference only
4. Front of the cabinet is identified as the side from which the cabinet will open and will be indicated on the construction drawing. Future ducts are to be extended one foot beyond concrete encasement. Refer to the construction drawing for the direction of conduit placement.
5. See SR-215 for the trench and bend requirements.
6. All ducts require 3 inch minimum to 5 inch maximum concrete cap within 10 feet of the box pad. See SR-205 for duct and concrete requirements.
7. See SR-207 for the trench backfill requirements.
8. Installation of equipment protective barriers per SR-230 will be required (refer to construction drawing) where cabinet is exposed to vehicular traffic or as determined by Design Services.
9. A gradual transition slope from the 48 inch trench depth to the 76 inch box pad trench depth is required.
10. Customer to provide and install two- 5/8" x 8'-0", copper clad, ground rods prior to concrete being poured. The top 24 inches of the ground rod shall extend above the sub-grade within the opening of the box pad. See Figure 1 for placement.
11. Ground rods are to have impalement safety covers, (per Federal OSHA 701(B) and California OSHA #C1718AG and OSHA 1723AG, for rebar #3 and #8).
12. If installation of a sweep is required into an existing J6 cabinet, an access crew appointment is required to provide assistance and proper placement. Refer to SR-106 for scheduling information.
13. Conduit positions 1 and 2 are the default location. When a PME cabinet (SR-240) is installed in conjunction with the J6 cabinet (SR-236), conduit positions 2 and 3 are the default to be routed to the PME cabinet. Refer to construction drawing for details on conduit placement.

		INITIATED BY	TRM	REVISION NO.	0	SR-236 Pg. 3 of 3
		ESR COMM.	10-25	ESR COMM.	-	
				EFFECTIVE DATE	-	