

EXCAVATION AND DUCT PLACEMENT FOR 1Ø JUNCTION CABINET (J1)

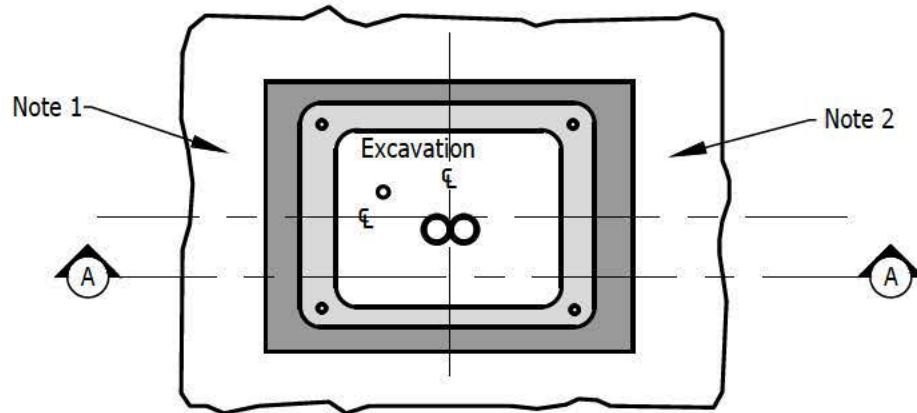

TOP VIEW - JUNCTION CABINET SITE

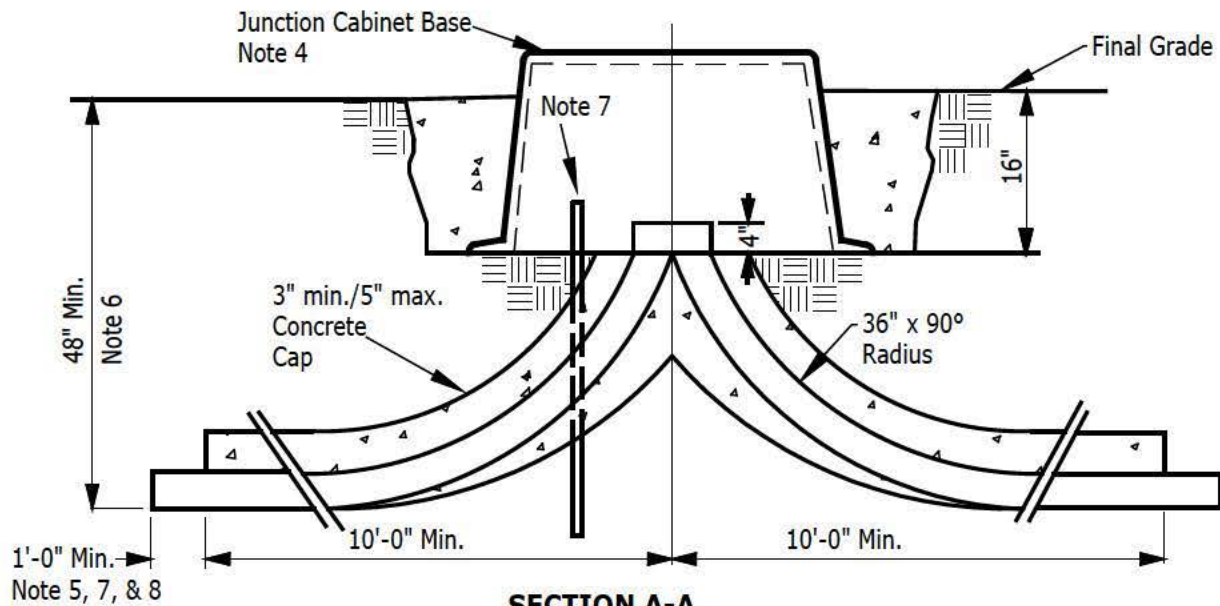

SECTION A-A

NOTES:

1. Customer to provide excavation (36" W x 36" D x 16" Deep) for junction cabinet placement. Soil must be compacted and level. Site preparation per SR-208.
2. See SR-209, Page 5 for placement and trenching, SR-207 for Trench Backfill.
3. Install an equipment protective barrier per SR-230 where cabinet is exposed to vehicular traffic.
4. The junction cabinet base is an integral part of the cabinet and will be provided by TEP and installed and backfilled by the customer. Base to be picked up by customer at District Office.
5. Customer to provide and install the 2 1/2 inch duct run(s) and 2 1/2 inch duct sweep(s) for future duct run(s) as depicted on the TEP construction drawing. Sweeps for future duct runs are to always be placed to the front center of the junction cabinet base excavation (front being the side from which the junction cabinet will open, which will be shown on the construction drawing). Sweeps are to extend 1 ft. beyond their concrete encasement for future attachment.
6. Transition from 48 inch depth to 36 inch trench depth to be a gradual slope.
7. Customer to install a 5/8" x 8'-0" copper coated ground rod prior to concrete being poured. The top of the rod shall be 6 inches above sub-grade. The ground rod shall be provided by TEP.
8. Conduit (duct run or sweeps) only as required, refer to the construction drawing.